



GALSUSA
galvanizados del sureste, s.a

De Chapa y Emparrillados

Puertas de Mallazo Liso

i CARACTERÍSTICAS TÉCNICAS

Bastidor o marco realizado con tubo cuadrado 1.5 mm. y perfil aleta grande.

Pilares laterales para anclaje de la puerta compuestos por tubo cuadrado de 100-120 de 3 a 5 mm. de espesor (según medidas).

Cierre del bastidor con emparrillado electrosoldado 60x120 25x3 mm., mallazo electrosoldado 50x150x5 mm. ó con material a juego conjunto verja.

El sistema de cierre es de manivela con cerradura.



? APLICACIONES

Puerta diseñada para ser colocada en cualquier cerramiento metálico compuesto por paneles enmarcados o sin enmarcar.



∇ ACABADOS

Galvanizado en Caliente UNE-EN ISO 1461 o Galvanizado + Pintado Poliéster.

Certificación de Conformidad de la Producción:
CPG-0000021



C/ Blanca, s/n Pol. La Polvorista
30500 Molina de Segura. Murcia



968 611 974
FAX 968 611 858



info@galsusa.es



www.galsusa.es



GALSUSA
galvanizados del sureste, s.a

De Chapa y Emparrillados

Puertas de Mallazo Liso

→ DIMENSIONES

Nominal	Hojas	Apertura	Ancho Total	Altura Real
1x1.50 m	1	Decha/Izda	0,99 m	1,54 m
1x1.80 m	1	Decha/Izda	0,99 m	1,83 m
1x2.00 m	1	Decha/Izda	0,99 m	2,03 m
2x2.00 m	2	Interior	2,00 m	2,03 m
3x1.80 m	2	Interior	3,00 m	1,83 m
3x2.00 m	2	Interior	3,00 m	2,03 m
4x1.80 m	2	Interior	4,04 m	1,83 m
4x2.00 m	2	Interior	4,04 m	2,03 m
5x2.00 m	2	Interior	5,04 m	2,03 m
6x2.00 m	2	Interior	6,08 m	2,03 m

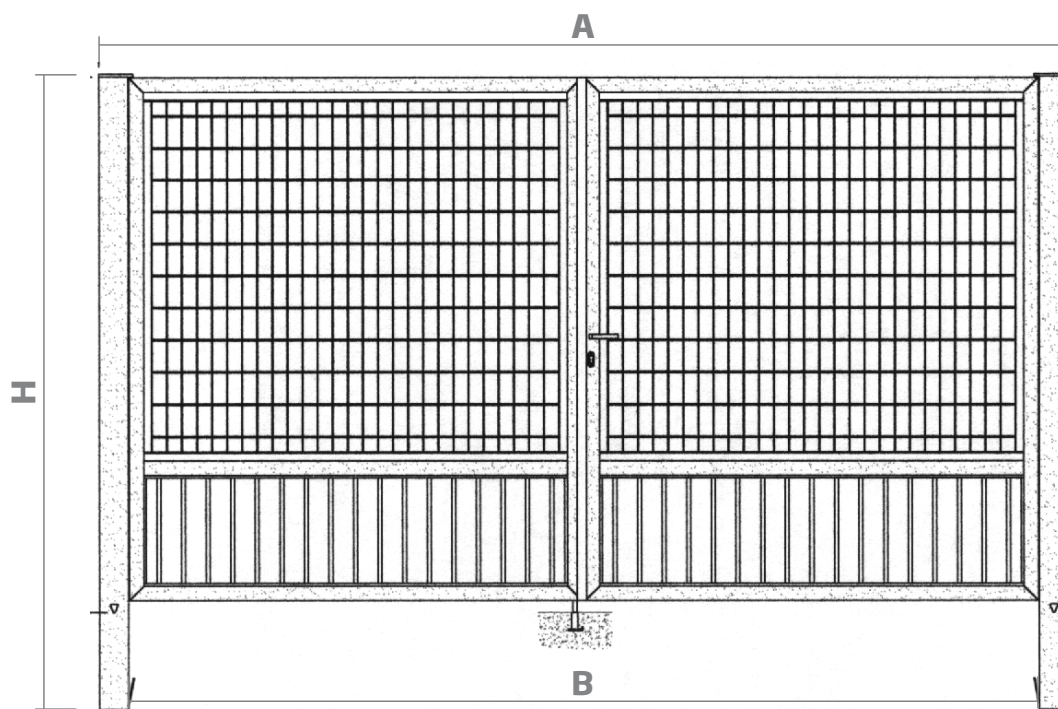

Certificación de
Conformidad de
la Producción:
CPG-0000021



C/ Blanca, s/n Pol. La Polvorista
30500 Molina de Segura. Murcia



968 611 974
FAX: 968 611 858



info@galsusa.es



www.galsusa.es



GALSUSA
galvanizados del sureste, s.a

Cerramientos Modulares

Verja de Emparrillado

i CARACTERÍSTICAS TÉCNICAS

Fabricada con emparrillado ELECTRO-SOLDADO:

Malla 60x120 mm., nominal 62x132 mm. a ejes,
pletina portante 25x2 mm. y redondo liso Ø 5 mm.

Malla 60x60 mm., nominal 62x66 mm. a ejes,
pletina portante 25x2 mm. y redondo liso Ø 5 mm.

Montantes en pletina 40x6 mm.

Postes de tubo 60x60x1.5 mm. con tapón metálico.

Uniones por atornillamiento en acero inoxidable.

Disponible en tres alturas, 1mt., 1.5 mts. y 2 mts.



∇ ACABADOS

Galvanizado en Caliente UNE-EN ISO 1461 ò Galvanizado
+ pintado en poliéster.



Certificación de
Conformidad de
la Producción:
CPG-0000021



C/ Blanca, s/n Pol. La Polvorista
30500 Molina de Segura. Murcia



968 611 974
FAX 968 611 858



info@galsusa.es



www.galsusa.es



GALSUSA
galvanizados del sureste, s.a

Cerramientos Modulares

Verja de Emparrillado

Q DETALLES VERJA EMPARRILLADO (mm)

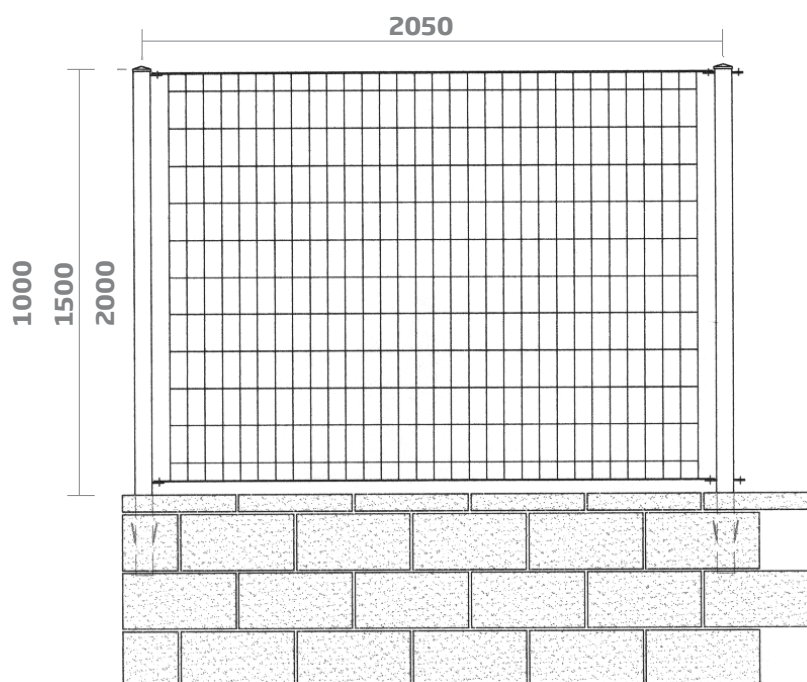

Q DETALLE SISTEMA DE ATORNILLAMIENTO (mm)

Cuerpo-poste.

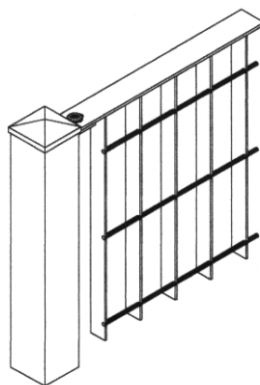

Certificación de
Conformidad de
la Producción:
CPG-0000021



C/ Blanca, s/n Pol. La Polvorista
30500 Molina de Segura. Murcia



968 611 974
FAX 968 611 858



info@galsusa.es



www.galsusa.es



GALSUSA
galvanizados del sureste, s.a

Cerramientos Modulares

Valla Móvil

i CARACTERÍSTICAS TÉCNICAS

Fabricada en alambre Ø 3 mm., malla de 150x125 mm. con cuatro pliegues longitudinales de refuerzo de 50x50 mm., para una mayor rigidez.

Puntas defensivas situadas en la parte superior.

Soportes laterales de tubo redondo acerado Ø 40x1.5 mm.

Disponible en altura de 1.9 mts.

Accesorios de fijación incorporados de instalación rápida mediante tornillo con tuerca M8x20.

Base de hormigón armado, provisto de seis agujeros para montar cualquier ángulo.

Reforzada con varilla 6 mm. para impedir roturas.

Peso Aprox. 34 Kgs.



∇ ACABADOS

Galvanizado en Caliente UNE-EN ISO 1461 ò Galvanizado + pintado en poliéster.

Certificación de Conformidad de la Producción:
CPG-0000021



C/ Blanca, s/n Pol. La Polvorista
30500 Molina de Segura. Murcia



968 611 974
FAX 968 611 858



info@galsusa.es



www.galsusa.es



GALSUSA
galvanizados del sureste, s.a

Cerramientos Modulares

Valla Móvil

DETALLES VALLA MOVIL (mm)

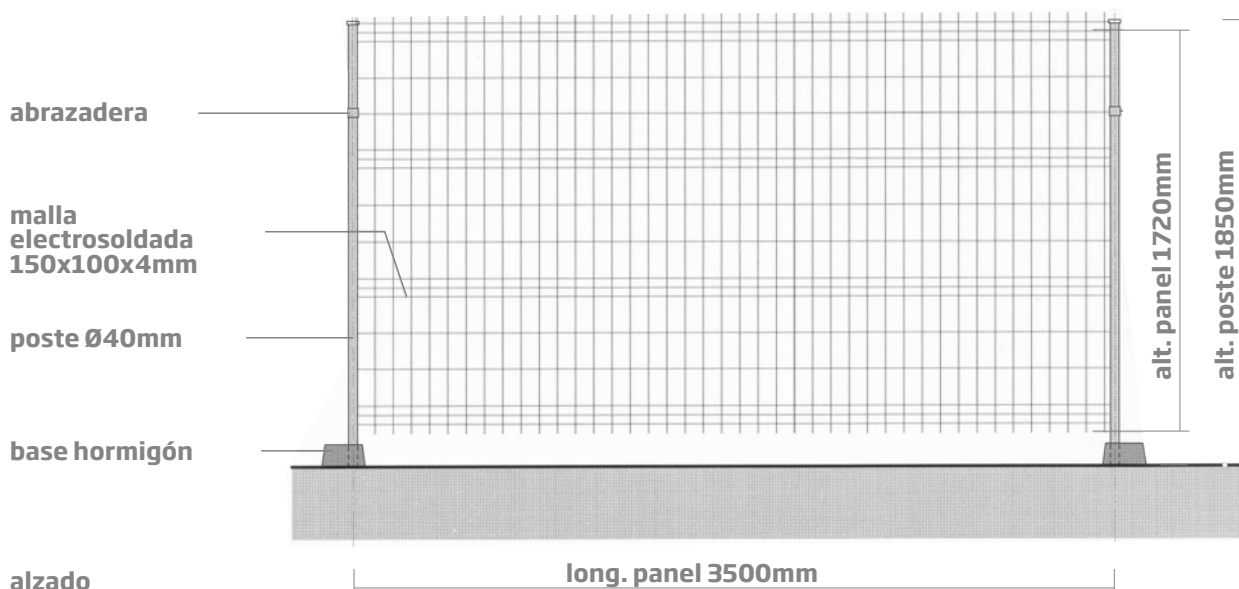

alzado

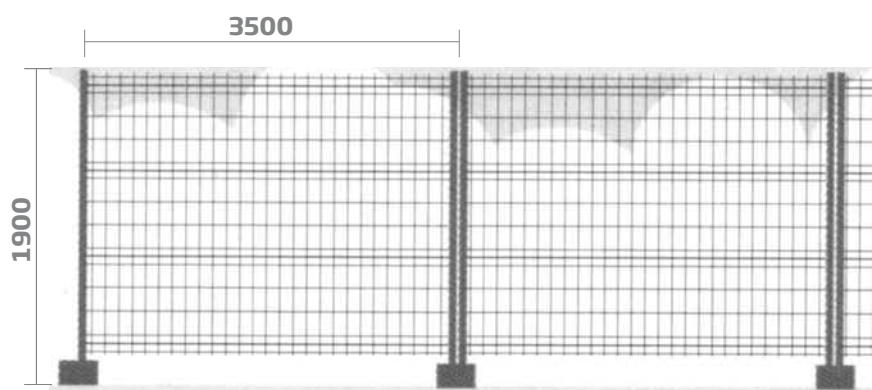

plegado



Certificación de Conformidad de la Producción:
CPG-0000021



C/ Blanca, s/n Pol. La Polvorista
30500 Molina de Segura. Murcia



968 611 974
FAX 968 611 858



info@galsusa.es



www.galsusa.es



GALSUSA
galvanizados del sureste, s.a

Cerramientos Modulares

Verja Plegada

i CARACTERÍSTICAS TÉCNICAS

Fabricada en alambre Ø 4.8 mm., malla de 200x55 mm. con pliegues de refuerzo de 50x50 mm.

Puntas defensivas situadas en la parte superior.

Postes de tubo 60x40x1,5 mm. con tapón superior de plástico.

Sistema de atornillamiento mediante abrazaderas con tapones plásticos para ocultar los tornillos.

Disponible en tres tipos de alturas, 1, 1.2, 1.5 y 2 mts.



∇ ACABADOS

Galvanizado en Caliente por inmersión UNE-EN ISO 1461.

Galvanizado en Caliente por inmersión UNE-EN ISO 1461 + pintado con poliéster

Pre-galvanizado.

Pre-galvanizado+Plastificado con poliéster (Blanco RAL 9010 ó Verde RAL 6005).

Otros colores bajo consulta.

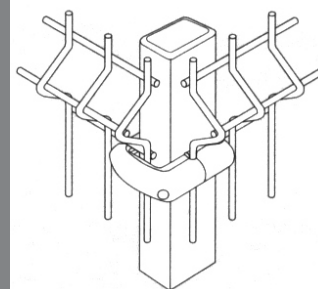

Certificación de Conformidad de la Producción:
CPG-0000021



C/ Blanca, s/n Pol. La Polvorista
30500 Molina de Segura, Murcia



968 611 974
FAX 968 611 858



info@galsusa.es



www.galsusa.es



GALSUSA
galvanizados del sureste, s.a

Cerramientos Modulares

Verja Plegada

→ DIMENSIONES (mm)

POSTE 60x40x1.5 mm		ABRAZADERAS
Altura Total	Altura Nominal	Nº por Poste
1.400	1,000	2
1.500	1,200	2
1.900	1,500	3
2.400	2,000	4

Distancia de colocación entre ejes 2515 mm

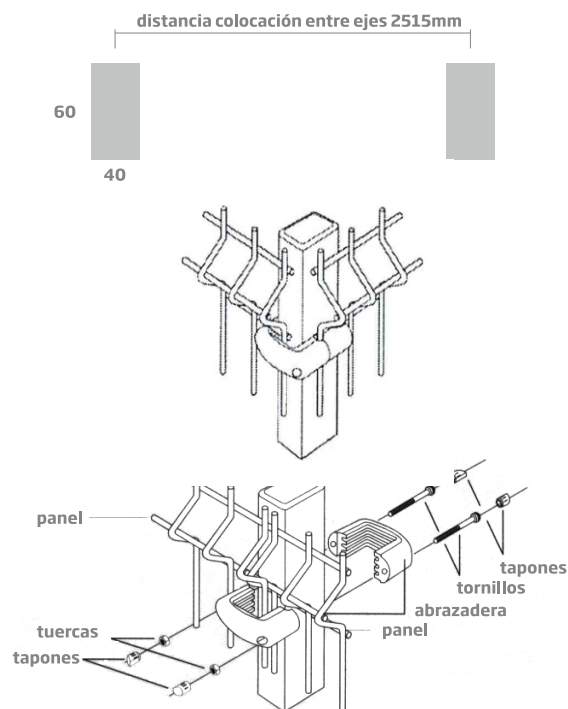
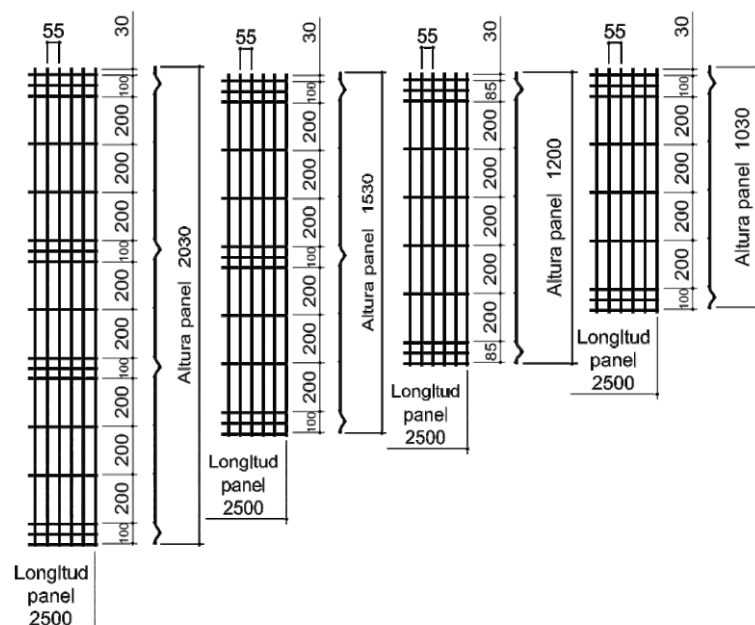

Certificación de Conformidad de la Producción:
CPG-0000021



C/ Blanca, s/n Pol. La Polvorista
30500 Molina de Segura, Murcia



968 611 974
FAX 968 611 858



info@galsusa.es



www.galsusa.es



GALSUSA
galvanizados del sureste, s.a

Verja Industrial de Mallazo

i CARACTERÍSTICAS TÉCNICAS

Fabricada con mallazo electrosoldado malla 150 x 50 y alambres de \varnothing 5 mm.

Bastidor fabricado con PDS-26 40 x 44 x 30 X 1,5 mm e

Pilastras de tubo rectangular 60 x 40 x 1,5 mm. con tapón superior de plástico.

Uniones por atornillamiento de acero inoxidable.

Disponible en dos alturas, 1.5 y 2 mts.



∇ ACABADOS

Galvanizado en Caliente UNE-EN ISO 1461 ó Galvanizado
+ Plastificado con poliéster.



Certificación de
Conformidad de
la Producción:
CPG-0000021



C/ Blanca, s/n Pol. La Polvorista
30500 Molina de Segura, Murcia



968 611 974
FAX 968 611 858



info@galsusa.es



www.galsusa.es



GALSUSA
galvanizados del sureste, s.a

Verja Industrial de Mallazo

Q DETALLES VERJA INDUSTRIAL (mm)

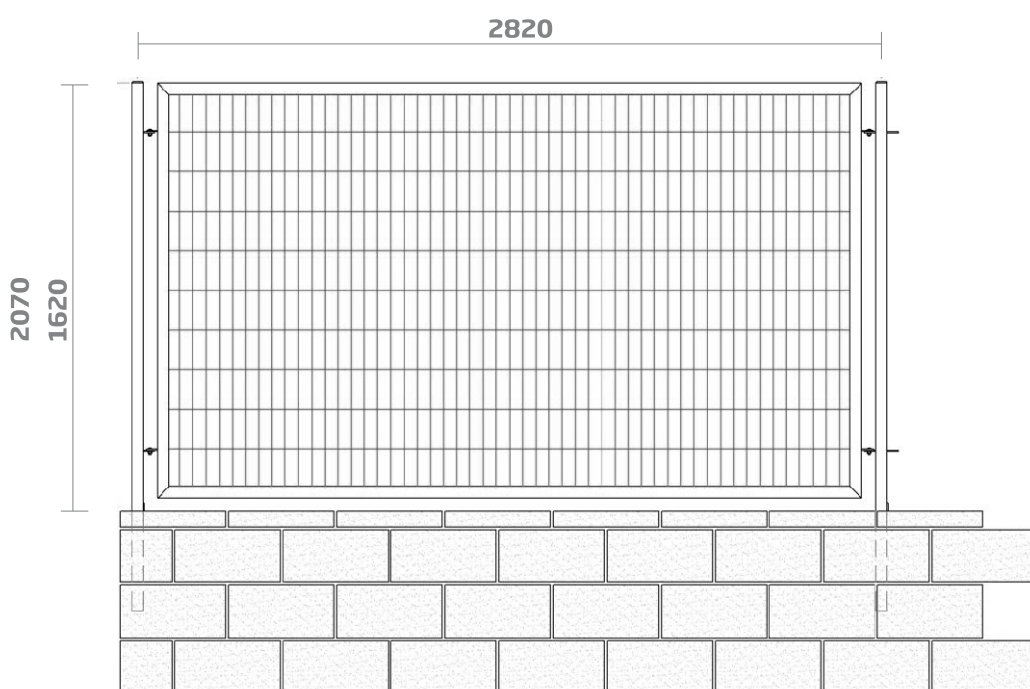

Q DETALLE SISTEMA DE ATORNILLAMIENTO (mm)

Cuerpo-poste.

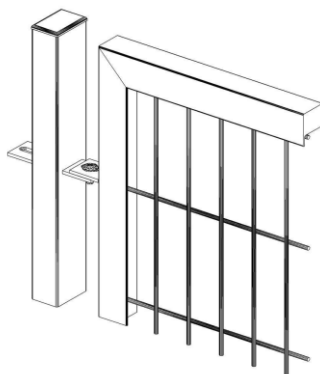

Certificación de
Conformidad de
la Producción:
CPG-0000021



C/ Blanca, s/n Pol. La Polvorista
30500 Molina de Segura, Murcia



968 611 974
FAX 968 611 858



info@galsusa.es



www.galsusa.es